

# Supplies

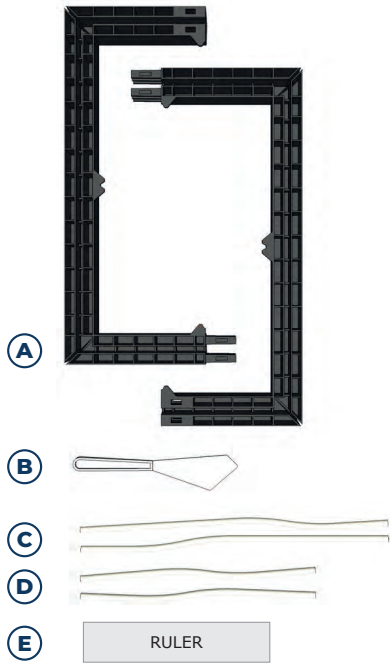

- A) 2 Canvas frame parts
- B) 1 Spatula
- C) 2 Long rubber laces
- D) 2 Short rubber laces
- E) Cardboard Ruler



Only use a canvas print with a thickness of 460 microns or more. This ensures a high quality finish.

# Preparations

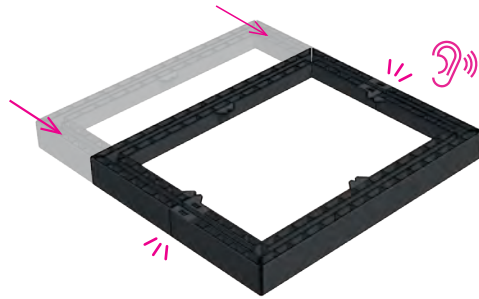

1 Assemble the canvas frame



2 Cut the canvas print to size, following the printed cutting lines

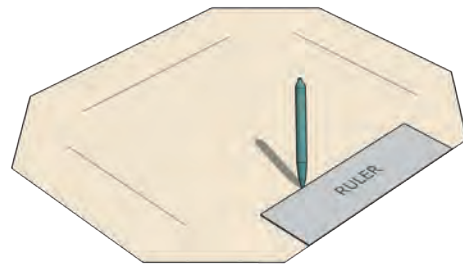

3 Take the ruler and mark with a pencil on the **backside** of the print the size of the canvas frame on 4 sides. Do not use a marker

# Canvas frame assembly

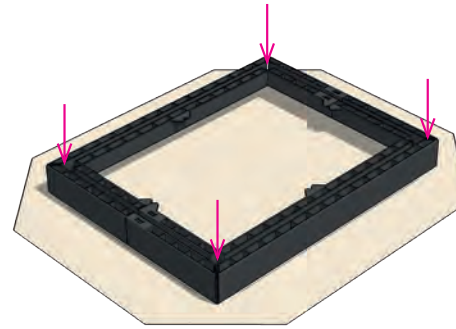

1 Place the canvas frame on top of the print, inside your markings



2 Tightly fold and hold the first long side of the print around the edge of the canvas frame

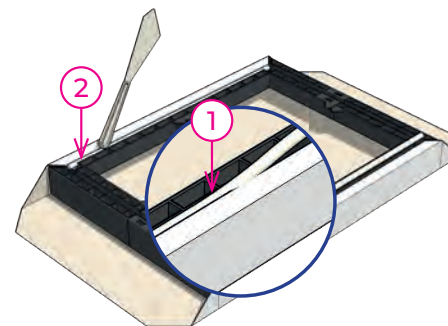

3 ① Holding the print, push the longest rubber lace in the holding space, to secure the canvas print. Repeat this step for the opposite side  
② Once both sides are done, push the laces all the way down, using the backside of the spatula

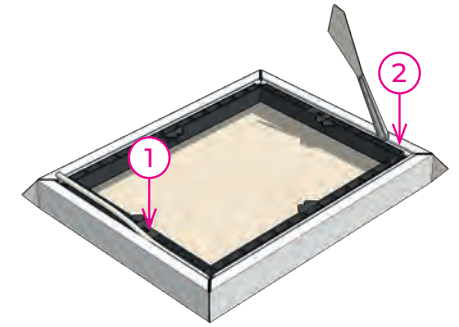

4 Fix both short sides using the short rubber laces, in the same way as the long edges

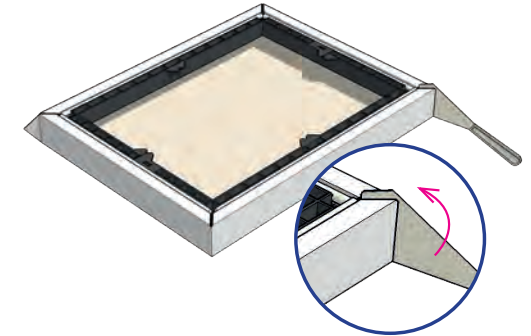

5 Push the corners of the print into the frame using the spatula. Your canvas is ready!